

soneil . n

Valve & Controls **DRESSER**

TABLE OF CONTENTS

1. Introduction	2	8. Actuator Range	7 - 8
2. General	2	Tables 1, 2, 3	7
3. Actuator Description	2	9. Air Action Changes	8 - 10
4. Unpacking	2	10. Actuator Installation on Valve Body and Plug stem Adjustments	10 - 11
5. Air Piping	2	Parts Reference	12
6. Actuator Removal	3 - 4	Table 4	13
7. Maintenance	4 - 7		

The following instructions should be thoroughly reviewed and understood prior to installing, operating or performing maintenance on this equipment. Throughout the text, safety and/or caution notes will appear and must be adhered to strictly; otherwise, serious injury or equipment malfunction could result.

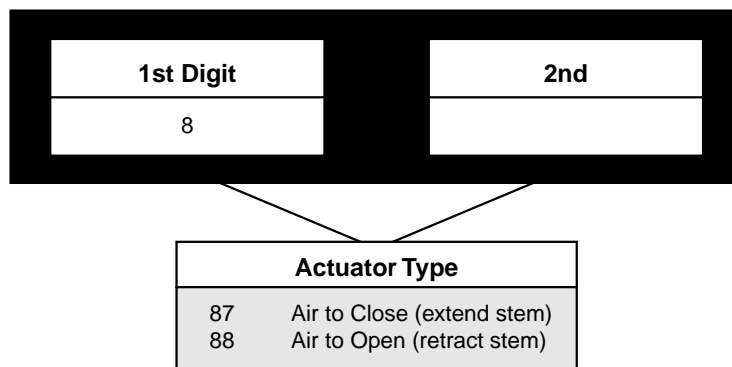

1. INTRODUCTION

The following instructions are designed to assist maintenance personnel in performing most of the maintenance required on the Model 87/88 actuator. Masoneilan has highly skilled service engineers available for start-up, maintenance and repair of our actuators and component parts. In addition, a regularly scheduled training program is conducted at the Training Center, to train customer service and instrumentation personnel in the operation, maintenance and application of our control valves and instruments. Arrangements for these services can be made through your Masoneilan Representative or Sales Office. When performing maintenance, use only Masoneilan replacement parts. Parts are obtainable through your local Masoneilan Representative or Sales Office. When ordering parts, always include Model and Serial Number of the unit being repaired.

2. GENERAL

These installation and maintenance instructions apply to the Masoneilan Model 87/88 actuator regardless of the valve body on which it is used. Actuator part numbers and recommended spare parts required for maintenance are listed in the Part Reference Table on page 12. The model number and action of the actuator are shown as part of the model number listed on the identification tag located on the actuator.

3. ACTUATOR DESCRIPTION

The 87/88 Series are pneumatic spring diaphragm actuators which feature field reversibility (with no additional parts). Because of its multiple spring design, four standard spring ranges are achieved by varying spring quantity and placement. A molded rolling diaphragm and deep cases minimize area change, effecting a linear relationship between travel and air pressure.

Caution: For full automatic operation, the handwheel must be placed in the neutral position. If the handwheel is not in the neutral position, travel will be limited.

4. UNPACKING

Care must be exercised when unpacking the equipment to prevent damage to the accessories and component parts. Should any problems arise, contact your Masoneilan Representative or District Office.

5. AIR PIPING

The Model 87/88 actuator is designed to accept 1/4" NPT air supply connections. If the actuator has been supplied with accessories, they are piped at the factory.

Caution: Do not exceed pressure indicated on identification tag.

6. ACTUATOR REMOVAL

Maintenance on the valve body normally requires removal of the valve actuator. The steps in removal of the actuator are different depending on whether the actuator is air to close or air to open.

Note: Actuator action may be checked by referring to the valve identification tag. Model 87 indicates unit is air to close and Model 88 indicates unit is air to open.

6.1 Air to close (Model 87), size 6, with or without handwheel (Figure 2)

- A. Shut off air supply to actuator and rotate handwheel to the neutral position. [No force exerted on the stem connector by the pivot pins (33)].
- B. Disconnect air piping from diaphragm case.
- C. Check the travel indicator (7) against the travel scale (9) to insure that the plug is up (off the seat).
Note: No air pressure is required to the actuator since the spring pressure tends to open the valve.
- D. Loosen stem lock nuts (1).
- E. Re-tighten lock nuts (1) against each other so they will lock at a point that is not against the stem connector (2).

Caution: At this time provisions must be made to support and lift the actuator off the body using recommended lift supports and procedures.

- F. Loosen and remove drive nut.

Caution: Depending on stem length, it may be required to slightly raise the actuator off the body to enable the plug stem to disengage from the actuator stem. The actuator must be raised straight off the body to prevent stress on the plug stem.

- G. Turn the stem lock nut (1) counterclockwise and loosen the plug stem until it disengages from the actuator stem (10).

Note: Do not allow the valve plug to drop or turn against the seat ring, as this could damage the seat and plug.

- H. Remove actuator from the valve body.

Caution: Care should be taken in handling the actuator to prevent damage to gauges, tubing, and component parts.

6.2 Air to open, Model 88, size 6, with handwheel

Caution: The stem connector (2) on this size is not fixed to the actuator stem and is a loose part with the plug stem removed. For safety, the handwheel must be in a free position and the actuator removed from the valve using procedure 6.3 Air to Open without handwheel.

6.3 Air to open (Model 88), size 6, no handwheel (Figures 2 and 4)

Since removal of the valve plug stem from the actuator stem connector requires that the valve plug be off the seat, special provisions are necessary to assure that the valve is in the opened position. The actuator do not being equipped with a handwheel, proceed as follows:

Note: Since air supply piping connected to the actuator is normally rigid and the actuator will be moved, it is required that a manual loading panel with suitable flex tubing be used or some suitable type of flex connections be made between the supply piping and the actuator connection.

Caution: Unreasonably high stress placed on rigid piping could cause breaking of the air supply line. A flex connector is required.

- A. Shut off air supply to the actuator.
- B. Disconnect air supply piping to the actuator.
- C. Connect manual loading panel tubing to the lower diaphragm case tubing connector.
- D. Apply required air pressure through the manual loading panel to open the valve as is indicated by the travel indicator (7) and travel indicator scale (9).

Caution: Do not exceed pressure indicated on the tag (63) on the diaphragm case.

- E. Loosen stem lock nuts (1).
- F. Re-tighten stem lock nuts (1) against each other so they will lock at a point that is not against the actuator stem connector (2).

Caution: At this time provisions must be made to support and lift the actuator off the body using recommended lift supports and procedures.

- G. Loosen and remove drive nut.

Caution: Depending on stem length, it may be required to slightly raise the actuator off the body to enable the plug stem to disengage from the actuator stem. The actuator must be raised straight off the body to prevent stress on the plug stem.

- H. Turn the upper stem lock nut (1) counterclockwise and unscrew the valve plug stem until disengaged from the actuator stem (10).

Note: Do not allow the plug to drop or turn against the seat ring. This could damage the seat and plug.

- I. Remove actuator from the valve body and shut off air supply pressure.

Caution: Care should be taken in handling the actuator to prevent damage to gauges, tubing, and component parts. In addition, since a flex connection is made between the actuator and air piping, care must be taken not to exert pressure on the flex tubing or air piping.

6.4 Air to close (Model 87), sizes 10-23, with and without handwheel (Figure 3)

- A. Shut off air supply to actuator and rotate handwheel to the neutral position.
- B. Disconnect air piping from diaphragm case.
- C. Check the travel indicator (7) against the travel scale (9) to insure that the plug is up (off the seat).

Note: No air pressure is required to the actuator since the spring pressure tends to open the valve.

- D. Loosen stem lock nut (1).
- E. Remove cap screws (5) from stem connector (2, 4).
Note: Do not allow the valve plug to drop or turn against the seat ring, as this could damage the seat and plug.

Caution: At this time provisions must be made to support and lift the actuator off the body using recommended lift supports and procedures.

- F. Loosen and remove drive nut.

Caution: Progressively raise actuator off the body to enable the top stem connector (4) disengage the bottom stem connector (2). The actuator must be raised straight off the body to prevent stress on the plug stem.

- G. Remove bottom stem connector parts (1, 2, 6) from plug stem.
- H. Remove actuator from the valve.

6.5 Air to open, Model 88, Size 10-23, with or without handwheel (Figure 4)

Since removal of the valve plug stem from the actuator stem connector requires that the valve plug be off the seat, special provisions are necessary to assure that the valve is in the opened position. Proceed as follows:

Note: Since air supply piping connected to the actuator is normally rigid and the actuator will be moved, it is required that a manual loading panel with suitable flex tubing be used or some suitable type of flex connections be made between the supply piping and the actuator connection.

Caution: Unreasonably high stress placed on rigid piping could cause breaking of the air supply line. A flex connector is required.

- A. Shut off air supply to the actuator and rotate handwheel to the neutral position.
- B. Disconnect air supply piping to the actuator.
- C. Connect manual loading panel tubing to the lower diaphragm case tubing connector.
- D. Apply required air pressure through the manual loading panel to open the valve as is indicated by the travel indicator (7) and stroke scale (9).

Caution: Do not exceed pressure indicated on the tag (63) on the diaphragm case.

- E. Loosen stem lock nuts (1).
- F. Remove cap screws (5) from stem connector (2, 4).
Note: Do not allow the valve plug to drop or turn against the seat ring, as this could damage the seat and plug.

Caution: At this time provisions must be made to support and lift the actuator off the body using recommended lift supports and procedures.

- G. Loosen and remove drive nut.

Caution: Progressively raise actuator off the body to enable the top stem connector (4) disengage the bottom stem connector (2). The actuator must be raised straight off the body to prevent stress on the plug stem.

- H. Remove bottom stem connector parts (1, 2, 6) from plug stem.
- I. Remove actuator from the valve and shut off air supply pressure.

7. MAINTENANCE

Caution: It is recommended that disassembly or assembly work on these actuators be done in an upright position.

7.1 Replacing diaphragm air to open actuators (Model 88) with or without handwheel (Figure 4)

- A. Shut off air supply to the actuator, isolate the control valve process pressure to eliminate the valve from moving with spring tension removed.
- B. If valve is equipped with a handwheel, rotate handwheel to a neutral position.
- C. Remove diaphragm case cap screws and nuts (20 and 19).

Caution: Diaphragm case is under spring tension and is equipped with tension bolts (27, 28 and 56) which must be removed last.

- D. Remove tension bolts (27, 28 and 56) in multiple steps to relieve spring tension gradually. Remove upper diaphragm case (24).
- E. Note position of springs (21) and spring spacers (18) [if equipped] in the diaphragm plate (26), before to remove these parts.
- F. Remove cap screw (23) [size 6] or jam nut (23) [all other sizes] and diaphragm washer (22) [all sizes].
- G. Remove diaphragm plate (26) and diaphragm (25).
- H. Replace the new diaphragm (25) on the diaphragm plate (26).
- I. Size 6 actuator coat the threads of cap screw (23) and

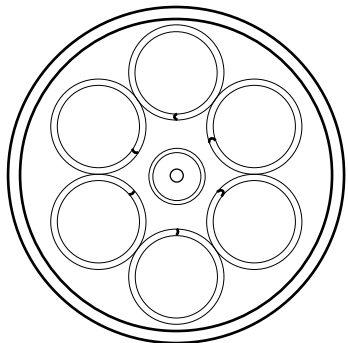

Figure 1

the surfaces of washer (22) with Dupont Sealant Compound III or equal. All other sizes, coat the actuator stem threads (10) and the surfaces of washer (22) with Dupont Sealant Compound III or equal.

- J. Checking placement of spacer (14), reassemble diaphragm (25), diaphragm plate (26), washer (22) then tighten fastener (23) in proper locations.

- K. Position springs (21) and spring spacers (18) [if used] in the diaphragm plate.

Note: Arrange springs so that the coil ends are pointed toward the actuator stem as shown in Figure 1. This step assures best actuator performance.

- L. Replace upper diaphragm case (24) and tension bolts (27, 28 and 56).

Note: Tension bolts should be spaced equally around the bolt circle of the case.

- M. Tighten the tension bolts (27, 28 and 56) in equal steps until the cases meet. Replace the remaining cap screws (20) and nuts (19).

Caution: Tighten cap screws and nuts evenly. Do not over-tighten as this could possibly warp the diaphragm cases. See Table 3 for torque values.

- N. If so equipped, rotate handwheel to the desired position.

7.2 Replacing diaphragm air to close (Model 87) actuator with handwheel (Figures 2 or 3 and 7)

Caution: The handwheel assembly can hold spring tension in the actuator when the diaphragm case is removed. To prevent possible injury, remove handwheel per the following procedure.

- A. Shut off air supply to the actuator, isolate the control process pressure to eliminate the valve plug from moving with spring tension removed.
- B. Rotate the handwheel (41) to a neutral position.
- C. Remove two handwheel pivot pins (33) which are

mounted through the yoke and secure the handwheel pivot (36) in place (see Figure 7).

- D. Let the complete handwheel assembly swing down and out of the way of the top stem connector (4) [bottom stem connector (2) on size 6 actuator].
- E. Proceed with the instructions for air to close actuators without handwheel (7.3).

7.3 Replacing diaphragm air to close (Model 87) actuator without handwheel (Figures 2 or 3 and 7)

- A. Shut off air supply to the actuator and remove air piping from the upper diaphragm case (24).
- B. Remove the two socket head cap screws (5) which hold the top and bottom stem connector (2 and 4) together.

Note: The size 6 actuator only has a bottom stem connector. For diaphragm replacement, the stem lock nuts (1) must be loosened. The plug stem is turned out at the actuator stem (10) in order to allow the actuator stem to rise with release of spring tension. Depending on stem length, it may be required, to allow this step, to separate the size 6 actuator off the valve body, as indicated in Section 6.1.

- C. Remove diaphragm case cap screws and nuts (20 and 19).

Caution: Diaphragm case is under spring tension and is equipped with tension bolts (27, 28 and 56) which must be removed last.

- D. Remove tension bolts (27, 28 and 56) in multiple steps to relieve spring tension gradually. Remove upper diaphragm case (24).
- E. Remove cap screw (23) [size 6] or jam nut (23) [all other sizes] and diaphragm washer (22) [all sizes].
- F. Replace new diaphragm (25) on the diaphragm plate (26).
- G. Size 6 actuator, coat the threads of cap screw (23) and the surfaces of washer (22) with Dupont Sealant Compound III or equal. All other sizes, coat the actuator stem threads (10) and the surfaces of washer (22) with Dupont Sealant Compound III or its equivalent. Install washer (22) and tighten fastener (23).

- H. Replace upper diaphragm case (24) and tension bolts (27, 28 and 56).

Note: Tension bolts should be spaced equally around the bolt circle of the case.

- I. Tighten the tension bolts (27, 28 and 56) in equal steps until the cases meet. Replace the remaining cap screws (20) and nuts (19).

Caution: Tighten cap screws and nuts evenly. Do not overtighten as this could possibly warp the diaphragm cases. See Table 3 for torque values.

- J. Position top and bottom stem connectors (2 and 4) and replace the two socket head cap screws (5) and recalibrate the seated position of the valve (Section 10.2).

Note: Size 6 actuator - Screw the plug stem back into the actuator stem (10) thru the bottom stem connector and recalibrate the seated position of the valve. If the actuator has been removed from the valve body, re-install it as indicated in Section 10.2).

Note: If the actuator has a handwheel (Section 7.2), continue with the following steps:

- K. Swing handwheel assembly back up into place.
- L. Install the two pivot pins (33) in the yoke and engage them into the handwheel pivot (36).

7.4 Replace or repack handwheel bearing, size 6 and 10 actuators (Figures 5 and 7)

- A. Rotate handwheel to a free position.
- B. Remove handwheel cap screw (20) and washer (42).
- C. Remove handwheel (41) and lock nut (43).
- D. Remove pivot pins (33) from the yoke which hold the handwheel pivot (36).
- E. Remove snap rings (46) and remove lever pin (45) to release handwheel assembly.
- F. Turn handwheel stem (39) until it clears traveling nut (40).
- G. Remove snap ring (38) and bearing ring (37) to release the handwheel stem (39) from the bearing.
- H. Remove snap ring (35) to release bearing (34).
- I. Replace or clean to repack bearing (34) with new grease.
- J. Bearing should be packed with Mobilux No. 2 grease or equal.

Note: It is important that bearing be packed, not just coated, with grease.

- K. To reassemble, reverse removal procedures from step (H) through (B).

7.5 Replace or repack handwheel bearing size 16 and 23 actuators (Figures 6 and 7)

- A. Rotate handwheel to a free position.
- B. Remove pivot pins (33) which engage the handwheel pivot (36) thru the yoke.
- C. Remove snap rings (46) and remove lever pin (45) to release complete handwheel assembly.
- D. Remove snap ring (35) and slide the handwheel pivot (36) off the bearing (34).

- E. Remove cap screw (38) and end flange (37). This will release the bearing (34).
- F. Replace or clean to repack the bearing with new grease.
- G. Pack bearing (34) with Mobilux No. 2 grease or equal.
Note: It is important that the bearing be packed, not just coated, with grease.
- H. For remounting, reverse removal procedures from step (E) through (B).

7.6 Replace diaphragm seal and stem seal, air to open (Model 88) actuators (Figure 2 or 4)

- A. Shut off air supply to the actuator, isolate the control valve process pressure to eliminate the valve from moving with spring tension removed.
- B. If valve is equipped with a handwheel, rotate handwheel to a free position.
- C. Remove diaphragm case cap screws and nuts (20 & 19).

Caution: Diaphragm case is under spring tension and is equipped with tension bolts (27, 28 and 56) which must be removed last.

- D. Remove tension bolts (27, 28 and 56) in multiple steps to relieve spring tension gradually. Remove upper diaphragm case (24).
- E. Note position of springs (21) and spring spacers (18) [if equipped] in the diaphragm plate (26).
- F. Remove springs (21) and spring spacers (18) if used.

On size 6 Actuator:

- G. Loosen lock nuts (1). Re-tighten lock nuts against each other so they will lock at a point that is not against the stem connector (2). By means of a wrench, hold the nuts (1) and plug stem. Turn the actuator stem (10) subassembly until it disengages from the plug stem and remove completely from actuator.

On size 10, 16 and 23 Actuators:

- G. Loosen lock nut (32) on actuator stem (10). Hold the connector device (2, 4, 6). Turn the actuator stem (10) subassembly and remove it when it clears the connector insert (6), (on size 6), or the top stem connector (4), (on sizes 16 and 23).

On all sizes:

- H. Remove case cap screws (16) to gain access to seal washers (15).

Note: If seal washers (15) replacement is the only maintenance, proceed to Step N.

- I. Remove lower diaphragm case (17) and stem bushing (30).

Note: Mark orientation of the case to the yoke.

- J. Replace stem wiper (11) and O-rings (12 and 13).

- K. Coat O-rings (12 and 13) and inside of stem bushing (30) with Dupont Compound III (or equivalent).
- L. Install stem bushing (30) in the yoke with new O-rings (12 and 13).
- M. Place the diaphragm case (17) on the yoke.
- N. Coat the surface of the spring guides (29) in contact with the diaphragm case with Dupont Sealant Compound III or equivalent. Assemble spring guides (29), new seal washers (15), and cap screws (16) in this order.
- O. Re-install the actuator stem (10) subassembly into the yoke bushing. Turn actuator stem into insert (6), (size 10), or into the top stem connector (4), (size 16 and 23). In case of size 6 actuator, turn actuator stem on the plug stem after installing the stem connector (2). Turn until stem spacer (14) contacts the lower diaphragm case (17).
- P. Tighten lock nut (32) against connector insert (6), (size 10), or against the top stem connector (4), (on sizes 16 and 23). In case of size 6 actuator, lock the stem connector (2) and the two nuts (1) against the lower part of actuator stem.
- Q. Position springs (21) and spring spacers (18) [if used] in the diaphragm plate.

Note: Arrange springs so that the coil ends are pointed toward the actuator stem as shown in Figure 1. This step assures best actuator performance.
- R. Replace upper diaphragm case (24) and the tension bolts (27, 28 and 56).

Note: Tension bolts should be spaced equally around the bolt circle of the case.
- S. Tighten the tension bolts (27, 28 and 56) in equal steps until the cases meet. Replace the remaining cap screws (20) and nuts (19).

Caution: Tighten cap screws and nuts evenly. Do not over-tighten as this could possibly warp the diaphragm cases. See Table 3 for torque values.

- T. If necessary, recalibrate the seated position of the valve (Section 10.1).

TABLE 1

ACTUATOR TRAVEL in. (mm)	SPRING COLOR
20 (0.8)	RED
38 (1.5)	BLUE
51 (2.0)	GREEN
64 (2.5)	YELLOW

TABLE 2

SPRING RANGE psi (m.bar)	NO. OF SPRINGS REQUIRED	SPRING POSITION ON DIAPHRAGM PLATE	SPRING SPACER (18) REQUIRED
3-15 (0.207-1.034)	3	BOTTOM	NO
6-30 (0.414-2.069)	6	BOTTOM	NO
11-23 (0.759-1.586)	3	PEDESTAL	YES*
21-45 (1.448-3.103)	6	PEDESTAL	YES*

* A spring spacer (18) is required on Size 10 for 1.5in. (38mm) travel only and on Sizes 16 and 23, for 1.5in. (38mm), 2.0in. (51mm) and 2.5in. (64mm) travels.

TABLE 3

Bolt/Nut Reference	Actuator Size			
	6	10	16	23
Yoke Cap Screw (16)	13.5 <i>(120)</i>	21.5 <i>(190)</i>	45 <i>(400)</i>	68 <i>(600)</i>
Case Bolt (19, 20) or Tension Bolt (27, 28)	7.5 <i>(65)</i>	12.5 <i>(110)</i>	17 <i>(150)</i>	19 <i>(170)</i>
Actuator Stem Nut (23) or Cap Screw (23)	3.5 <i>(25)</i>	7.5 <i>(55)</i>	13 <i>(95)</i>	20.5 <i>(150)</i>
Socket Head Cap Screw (5)	—	4.5 <i>(35)</i>	17 <i>(125)</i>	17 <i>(125)</i>
Stem Jam Nut (1, 32)	3.5 <i>(25)</i>	7.5 <i>(55)</i>	13 <i>(95)</i>	20.5 <i>(150)</i>
Pivot Pin (33)	8 <i>(60)</i>	8 <i>(60)</i>	11 <i>(80)</i>	11 <i>(80)</i>
Handwheel Cap Screw (20)	7.5 <i>(65)</i>	7.5 <i>(65)</i>	17 <i>(150)</i>	17 <i>(150)</i>
Handwheel Stem Cap Screw (38)	—	—	13.5 <i>(100)</i>	13.5 <i>(100)</i>

Numbers in standard type without parenthesis are in daN.m, numbers in standard type with parenthesis () are in foot pounds.

Numbers in italic type without parenthesis are in N.m; Numbers in italic type with parenthesis () are in inch pounds.

The listed values are nominal torques; Tolerance is: ± 10%

8. ACTUATOR RANGE

8.1 Actuator range change, air to open (Model 88).

- A. Shut off air supply to the actuator, isolate the control valve process pressure to eliminate the valve from moving with spring tension removed.
- B. If valve is equipped with a handwheel, rotate handwheel to a free position.
- C. Remove diaphragm case cap screws and nuts (20 and 19).

Caution: Diaphragm case is under spring tension and is equipped with tension bolts (27, 28 and 56) which must be removed last.

- D. Remove tension bolts (27, 28 and 56) in multiple steps to relieve spring tension gradually. Remove upper diaphragm case (24).
- E. Position springs (21) [and spring spacers (18), if new range uses them], in the diaphragm plate.
- F. Refer to Tables 1, 2 and 4 for spring information :
 - a. For 11 and 21 psi (0,759 and 1,448 bar) initials, the springs are placed directly on the upper pedestals in the diaphragm plate (26).
 - b. For 3 and 6 psi (0.207 and 0.414 bar) initials, the springs are placed in the bottom cavity in the diaphragm plate.

- c. For 11 and 21 psi (0.759 and 1.448 bar) initials **and travel ranges larger than 0.8" (20 mm)**, the spring spacers (18) are placed as shown in the cross sectional view, Figure 4.

Note: Spring spacers (18) are not required for 0.8" (20 mm) travel ranges.

Note: Arrange springs so that the coil ends are pointed toward the actuator stem as shown in Figure 1. This step assures best actuator performance.

- G. Replace upper diaphragm case (24) and tension bolts (27, 28 and 56).

Note: Tension bolts should be spaced equally around the bolt circle of the case.

- H. Tighten the tension bolts (27, 28 and 56) in equal steps until the cases meet. Replace the remaining cap screws (20) and nuts (19).

Caution: Tighten cap screws and nuts evenly. Do not overtighten as this could possibly warp the diaphragm cases. See Table 3 for torque values.

- I. If so equipped, rotate handwheel to the desired position.

8.2 Actuator range change, air to close (Model 87)

Note: If actuator is equipped with a handwheel, please follow steps 7.2 A, B, C and D to disengage this assembly.

- A. Shut off air supply to the actuator and remove air piping from the upper diaphragm case (24).
- B. Remove the two socket head cap screws (5) which hold the top and bottom stem connector (2 and 4) together.

Note: The size 6 actuator only has a bottom stem connector (2). For access to springs, the stem lock nuts (1) must be loosened. The plug stem is turned out at the actuator stem (10) to allow the actuator stem to rise with release of spring tension. Depending on stem length, it may be required, to allow this step, to separate the size 6 actuator off the valve body, as indicated in Section 6.1.

- C. Remove diaphragm case cap screws and nuts (20 and 19).

Caution: Diaphragm case is under spring tension and is equipped with tension bolts (27, 28 and 56) which must be removed last.

- D. Remove tension bolts (27, 28 and 56) and compression nuts (28) in multiple steps to relieve spring tension gradually. Remove upper diaphragm case (24).
- E. Remove cap screw (23) [size 6] or jam nut (23) [all other sizes] and diaphragm washer (22).
- F. Remove diaphragm plate (26) and diaphragm (25).
- G. Place springs (21) over the spring guides (29).
- H. Refer to Tables 1, 2 and 4 for spring information:

- a. For 11 and 21 psi (0.759 and 1.448 bar) initials, the

springs are placed directly on the upper pedestals in the diaphragm plate (26).

- b. For 3 and 6 psi (0.207 and 0.414 bar) initials, the springs are placed in the bottom cavity in the diaphragm plate.

- c. For 11 and 21 psi (0.759 and 1.448 bar) initials **and travel ranges larger than 0.8" (20 mm)**, the spring spacers (18) are placed as shown in the cross sectional view, Figure 4.

Note: Spring spacers (18) are not required for 0.8" (20 mm) travel ranges.

Note: Arrange springs so that the coil ends are pointed toward the actuator stem as shown in Figure 1. This step assures best actuator performance.

- I. Replace the diaphragm plate (26) on the actuator stem (10) and over the springs. To ensure the springs are properly located, check the view hole in the diaphragm plate. A spring should be seen.

- J. Install the diaphragm (25).

- K. Size 6 actuator coat the threads of cap screw (23) and the surfaces of washer (22) with Dupont Sealant Compound III or equal. All other sizes, coat the actuator stem threads (10) and the surfaces of washer (22) with Dupont Sealant Compound III or equal.

- L. Replace upper diaphragm case (24) and the tension bolts (27, 28 and 56).

Note: Tension bolts should be spaced equally around the bolt circle of the case.

- M. Tighten the tension bolts (27, 28 and 56) in equal steps until the cases meet. Replace the remaining cap screws (20) and nuts (19).

Caution: Tighten cap screws and nuts evenly. Do not overtighten as this could possibly warp the diaphragm cases. See Table 3 for torque values.

- N. Position top and bottom stem connectors (2 and 4) and replace the two socket head cap screws (5) and recalibrate the seated position of the valve (Section 10.2).

Note: Size 6 actuator - Screw the plug stem back into the actuator stem (10) thru the bottom stem connector (2) and recalibrate the seated position of the valve. If the actuator has been removed from the valve body, re-install it as indicated in Section 10.2).

Note: If the actuator has a handwheel (Section 7.2), continue with the following steps:

- O. Swing handwheel assembly back up into place.

- P. Install the two pivot pins (33) in the yoke and engage them into the handwheel pivot (36).

9. AIR ACTION CHANGES

9.1 Air to Open to Air to Close (Model 88 to Model 87)

- A. Shut off air supply to the actuator, isolate the control valve process pressure to eliminate the valve from moving with spring tension removed.

- B. If valve is equipped with a handwheel, rotate handwheel to a neutral position.
- C. Remove snap rings (46) and remove lever pin (45) to allow handwheel assembly to swing away from the stem connector (2-4).
- D. Remove the two socket head cap screws (5) which hold the top and bottom stem connector (2 and 4) together.

Note: *The size 6 actuator only has a bottom stem connector (2). For changing of action, the stem lock nuts (1) must be loosened. The plug stem is turned out at the actuator stem (10) in order to allow the actuator stem to rise while springs installation in Model 87. Depending on stem length, it may be required, to allow this step, to separate the size 6 actuator off the valve body, as indicated in Section 6.3.*

- E. Remove diaphragm case cap screws and nuts (20 and 19).

Caution: Diaphragm case is under spring tension and is equipped with tension bolts (27, 28 and 56) which must be removed last.

- F. Remove tension bolts (27, 28 and 56) in multiple steps to relieve spring tension gradually. Remove upper diaphragm case (24). Remove springs (21) and spacer (18) if equipped.
- G. Remove cap screw (23) [size 6] or jam nut (23) [all other sizes] and diaphragm washer (22) [all sizes].
- H. Remove diaphragm plate (26) and diaphragm (25).
- I. Place springs (21) over the spring guides (29).
- J. Refer to Tables 1, 2 and 4 for spring information. Refer also to Section 8.1 F, Steps a., b., c.

Note: Spring spacers (18) are not required for 0.8" (20 mm) travel ranges.

Note: Arrange springs so that the coil ends are pointed toward the actuator as shown in Figure 1. This step assures best actuator performance.

- K. Invert and replace the diaphragm plate (26) on the actuator stem (10) and over the springs.

Note: To ensure the springs are properly located, check the view hole in the diaphragm plate. A spring should be seen.

- L. Install the diaphragm (25).
- M. Size 6 actuator coat the threads of cap screw (23) and the surfaces of washer (22) with Dupont Sealant Compound III or equal. All other sizes, coat the actuator stem threads (10) and the surfaces of washer (22) with Dupont Sealant Compound III or equal.
- N. Replace upper diaphragm case (24) and tension bolts (27, 28 and 56).

Note: Tension bolts should be spaced equally around the bolt circle of the case.

- O. Tighten the tension bolts (27, 28 and 56) in equal steps

until the cases meet. Replace the remaining cap screws (20) and nuts (19).

Caution: Tighten cap screws and nuts evenly. Do not over-tighten as this could possibly warp the diaphragm cases. See Table 3 for torque values.

- P. Position top and bottom stem connectors (2 and 4) and replace the two socket head cap screws (5) and recalibrate the seated position of the valve (Section 10.2).

Note: *Size 6 actuator - Screw the plug stem back into the actuator stem (10) thru the bottom stem connector (2) and recalibrate the seated position of the valve. If the actuator has been removed from the valve body, re-install it as indicated in Section 10.2.*

Note: If the actuator has a handwheel, continue with the following steps:

- Q. Swing handwheel assembly back up into place. The handwheel (41) may have to be turned in order to position the lower pivot pins (33).
- R. With the pivot pins positioned on top of the stem connector (2 and 4), replace the lever pin (45) and snap rings (46).

9.2 Air to Close to Air to Open, (Model 87 to Model 88)

Caution: The handwheel assembly can hold spring tension in the actuator when the diaphragm case is removed. To prevent possible injury, remove handwheel per the following procedure.

- A. Shut off air supply to the actuator, isolate the control process pressure to eliminate the valve from moving with spring tension removed.
- B. Rotate the handwheel (41) to a neutral position.
- C. Remove snap rings (46) and lever pins (45).
- D. The complete handwheel assembly can now swing out of the way of the top stem connector (2 and 4) [bottom stem connector (2) on the size 6 actuator].
- E. Proceed with the instructions for actuators without handwheel (9.3 Step B).

9.3 Air to Close to Air to Open (Model 87 to Model 88), without handwheel

- A. Shut off air supply to the actuator and remove air piping from the upper diaphragm case (24).
- B. Remove the two socket head cap screws (5) which hold the top and bottom stem connector (2 and 4) together.

Note: *The size 6 actuator only has a bottom stem connector. For changing of action, the stem lock nuts (1) must be loosened. The plug stem is turned out at the actuator stem (10) in order to allow the actuator stem to rise with release of spring tension, while disassembly.*

Depending on stem length, it may be required, to allow this step, to separate the size 6 actuator off the valve body, as indicated in Section 6.1.

- C. Remove diaphragm case cap screws and nuts (20 & 19).

Caution: Diaphragm case is under spring tension and is equipped with tension bolts (27, 28 and 56) which must be removed last.

- D. Remove tension bolts (27, 28 and 56) in multiple steps to relieve spring tension gradually. Remove upper diaphragm case (24).

- E. Remove cap screw (23) [size 6] or jam nut (23) [all other sizes] and diaphragm washer (22) [all sizes].

- F. Remove the diaphragm (25), diaphragm plate (26), springs (21) and spring spacers (18) if used.

- G. Invert the diaphragm (25) and diaphragm plate (26).

- H. Size 6 actuator coat the threads of cap screw (23) and the surfaces of washer (22) with Dupont Sealant Compound III or equal. All other sizes, coat the actuator stem threads (10) and the surfaces of washer (22) with Dupont Sealant Compound III or equal.

- I. Checking placement of spacer (14) reassemble diaphragm (25), diaphragm plate (26), washer (22) then tighten fastener (23) in proper locations.

- J. Position springs (21) and spring spacers (18) [if used] in the diaphragm plate.

- K. Refer to Tables 1, 2 and 4 for spring information. Refer also to Section 8.1 F, Steps a., b., c.

Note: Spring spacers (18) are not required for 0.8" (20 mm) travel ranges.

Note: Arrange springs so that the coil ends are pointed toward the actuator stem as shown in Figure 1. This step assures best actuator performance.

- L. Replace upper diaphragm case (24) and tension bolts (27, 28 and 56).

Note: Tension bolts should be spaced equally around the bolt circle of the case.

- M. Tighten the tension bolts (27, 28 and 56) in equal steps until the cases meet. Replace the remaining cap screws (20) and nuts (19).

Caution: Tighten cap screws and nuts evenly. Do not overtighten as this could possibly warp the diaphragm cases. See Table 3 for torque values.

- N. Position top and bottom stem connectors (2 and 4) and replace the two socket head cap screws (5) and recalibrate the seated position of the valve (Section 10.1).

Note: Size 6 actuator - Screw the plug stem back into the actuator stem (10) thru the bottom stem connector (2) and recalibrate the seated position of the valve. If the actuator has been removed from the valve body, re-install it as indicated in Section 10.1).

Note: If the actuator has a handwheel, continue with the following steps.

- O. Swing the handwheel assembly back into place.

- P. It may require turning the handwheel (41) to position the lower pivot pins (33) under the stem connector (2-4), [bottom stem connector (2) on the size 6 actuator].

- Q. Install the lever pin (45) and snap rings (46).

10. ACTUATOR INSTALLATION ON VALVE BODY AND PLUG STEM ADJUSTMENT

Caution: SIZE 6 - The stem connector (2) is not fixed to the actuator stem and is a loose part with the stem nuts (1) backed off. For safety reasons, adjustments should only be made pneumatically.

These installation and plug stem adjustment procedures are available for mounting of the Models 87/88 Actuators on most of the reciprocating and hard seat valves series. In case of the valves with spring loaded internal auxiliary tight shutoff plug (41400 Series), or valves with PTFE Soft seat ring, refer to instruction Add. No 184399 E or to the Section "Models 87/88 Actuators Coupling" on the specific instructions of the valve.

10.1 Air to open (Model 88)

- A. Connect manual loading panel tubing to the lower diaphragm case.

- B. Apply required air pressure through the manual loading panel to completely retract the actuator stem (10).

- C. Install actuator on the valve body with drive nut.

- D. Position top and bottom stem connectors (2 and 4) and replace the two socket head cap screws (5). Turn as far as possible the plug stem into lower part of the stem connector (2 or 6).

Note Size 6 actuator - Screw the plug stem into the actuator stem (10) thru the bottom stem connector (2). Depending on stem length, it may be required, to allow this step, to progressively lower the actuator towards the body, during screwing plug stem into actuator stem.

- E. Release air pressure, then ensure that the actuator stem is fully extended.

- F. Using the stem lock nuts (1), unscrew the plug stem until the plug touches the seat.

Caution: DO NOT TURN the plug against the seat as damage can occur.

- G. Pneumatically or with the handwheel, stroke the actuator to raise the plug off the seat. Unscrew the plug stem one full turn and lock the stem in place with the lock nut(s) (1) against the stem connector (2 or 6).

- H. Line up the stroke scale (9) with the pointer (7) and check actuator for operation.

10.2 Air to close (Model 87)

- A. Install actuator on the valve body with drive nut.
- B. Position top and bottom stem connectors (2 and 4) and replace the two socket head cap screws (5). Turn as far as possible the plug stem into lower part of the stem connector (2 or 6).

Note: Size 6 actuator - Screw the plug stem into the actuator stem (10) thru the bottom stem connector (2). Depending on stem length, it may be required, to allow this step, to progressively lower the actuator towards the body, during screwing plug stem into actuator stem.

- C. Pneumatically or with the handwheel, stroke the actuator to the rated spring range or stroke (if using the handwheel).
- D. Using the stem lock nuts (1) unscrew the plug stem until the plug touches the seat.

Caution: DO NOT TURN the plug against the seat, as damage can occur.

- E. Release the pressure in the actuator or back off the handwheel to raise the stem.
- F. Unscrew the stem 1/2 turn and lock the stem in place by tightening the stem nuts (1) against the stem connector (2 or 6).
- G. Line up the stroke scale (9) with the pointer (7) and check actuator for operation.

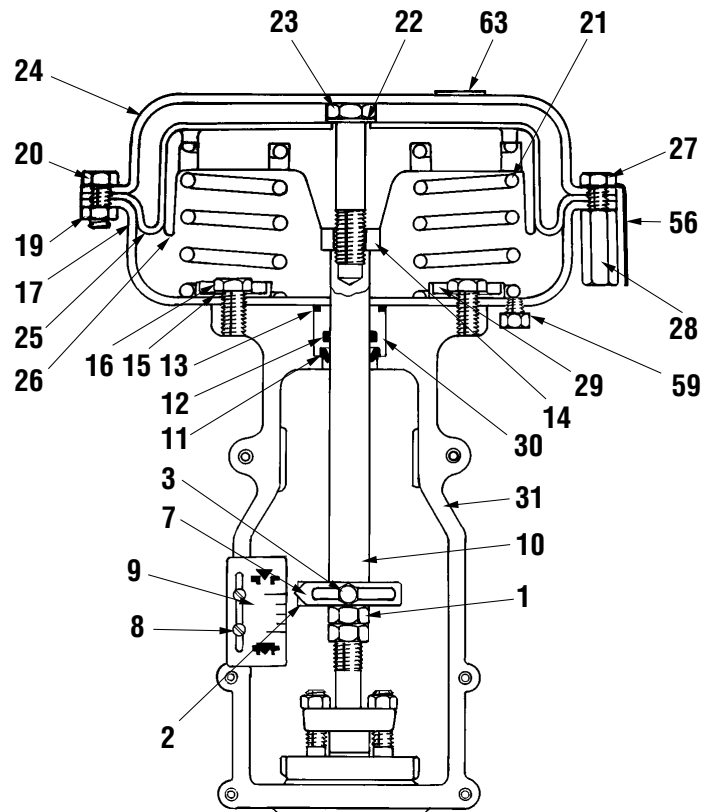

Figure 2
Size 6 Actuator Air to Close (Model 87)

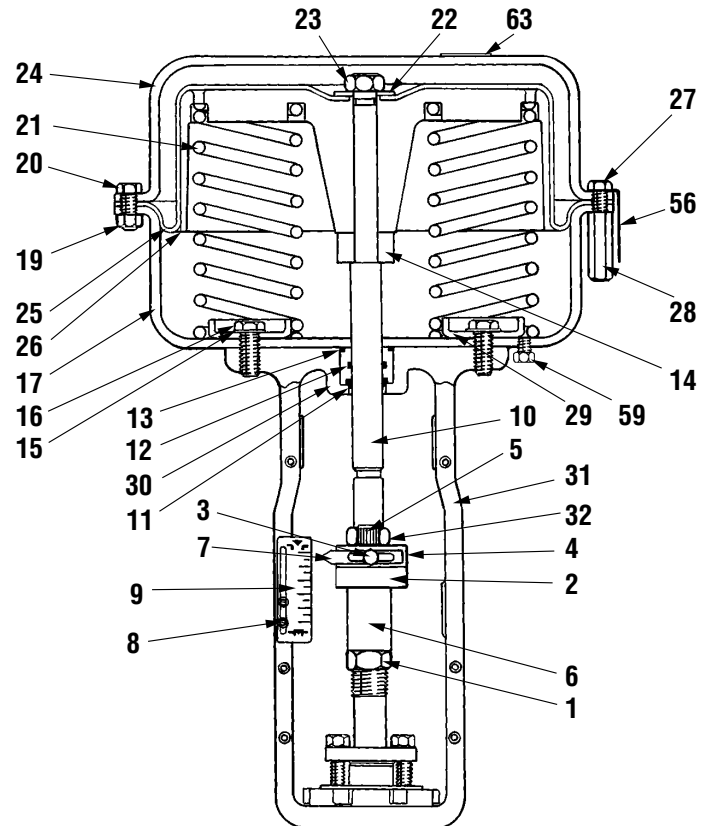

Figure 3
Size 16 Actuator Air to Close (Model 87)

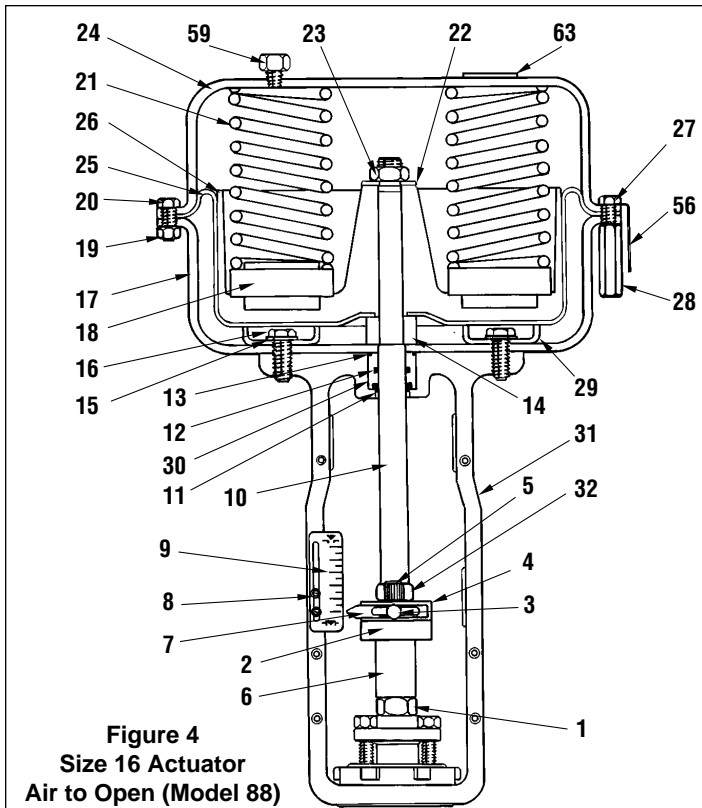

Figure 4
Size 16 Actuator
Air to Open (Model 88)

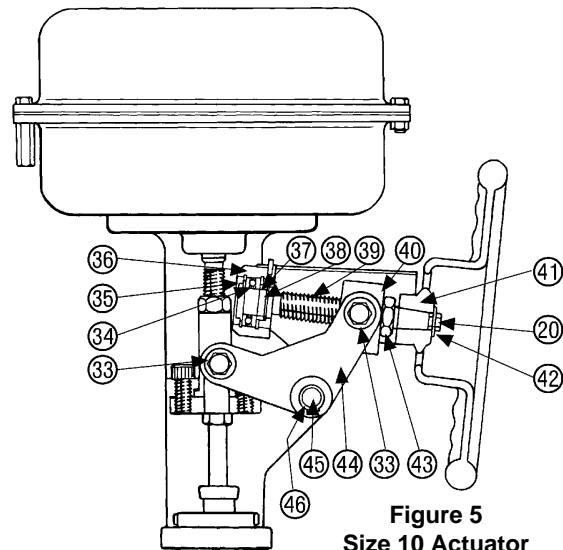

Figure 5
Size 10 Actuator
with optional Handwheel

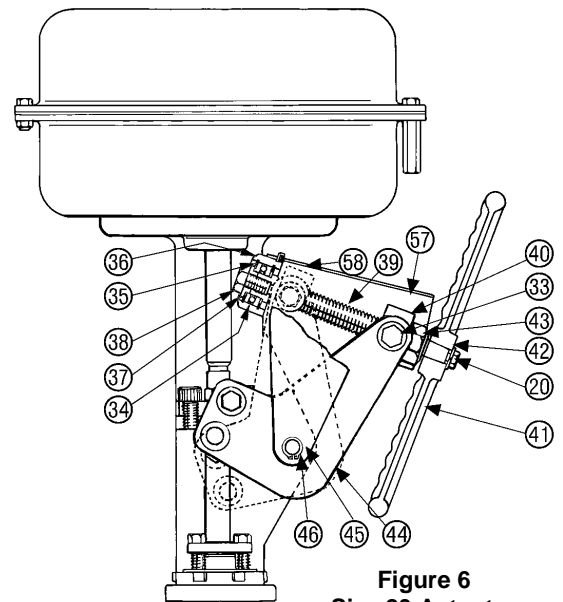

Figure 6
Size 23 Actuator
with optional Handwheel

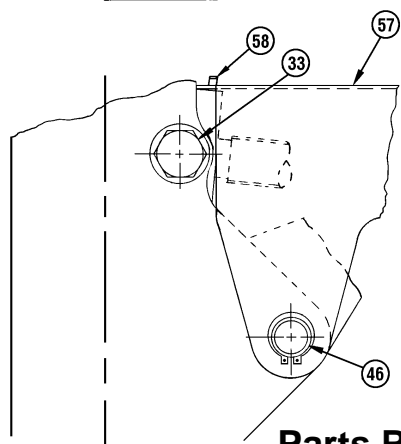

Figure 7
Handwheel Cover

Parts References

Ref. No	Description	Ref. No	Description	Ref. No	Description
1	Hex Nut	19	Hex Nut	▲37	<u>End Flange</u>
2	Stem Connector, bottom	20	Cap Screw, Hex head	▼38	<u>Cap Screw, Hex head</u>
3	Cap Screw, Hex head	21	Spring	39	<u>Handwheel Stem</u>
★4	Stem Connector, top	22	Washer	40	<u>Traveling Nut</u>
★5	Cap Screw, soc. head	■23	Nut, Jam	41	<u>Handwheel</u>
★6	Connector Insert	24	Upper Diaphragm Case	42	<u>Washer, Flat</u>
7	Pointer	●25	Diaphragm	43	<u>Lock Nut</u>
8	Screw, Pan head	26	Diaphragm Plate	44	<u>Handwheel Lever Assembly</u>
9	Scale - Travel	27	Cap Screw, Hex head	45	<u>Lever Pin</u>
10	Actuator Stem	28	Compression Nut	46	<u>Retaining Ring</u>
●11	Stem Wiper	29	Spring Guide	56	Warning Plate
●12	O-Ring	30	Stem Bushing	57	<u>Handwheel Cover</u>
●13	O-Ring	31	Yoke, machining	58	<u>Groove Pin</u>
14	Spacer	★32	Lock Nut	59	1/4" NPT Plug
●15	Seal Washer	33	<u>Pivot Pin</u>	61	Serial Plate (Not Shown)
16	Cap Screw, Hex head	34	<u>Thrust Bearing</u>	62	Drive Screw (Not Shown)
17	Lower Diaphragm Case	35	<u>Retaining Ring</u>	63	Caution Tag
★18	Spring Spacer	36	<u>Handwheel Pivot</u>		

● Recommended Spare Parts
★ Not provided for Size 6 Actuator
■ Hex Head Cap Screw on Size 6 Actuator
⓪ Not provided for 21 mm (.8 in.) travel
Underlined: Optional Handwheel Only

▲ Bearing Ring on Sizes 6 and 10
▼ Retaining Ring on Sizes 6 and 10

Actuator No.	Travel & Color Code	Range (psi)	Qty.	Springs Position
6	0.8" (20 mm) Red	3-15	3	A
		6-30	6	B
		11-23	3	C
		21-45	6	D
10	0.8" (20 mm) Red	3-15	3	A
		6-30	6	B
		11-23	3	C
		21-45	6	D
	1.5" (38 mm) Blue	3-15	3	A
		6-30	6	B
16	0.8" (20 mm) Red	3-15	3	A
		6-30	6	B
		11-23	3	C
		21-45	6	D
	1.5" (38 mm) Blue	3-15	3	A
		6-30	6	B
		11-23	3	E
		21-45	6	F
	2.0" (51 mm) Green	3-15	3	A
		6-30	6	B
		11-23	3	E
		21-45	6	F
2.5" (64 mm) Yellow	3-15	3	A	
	6-30	6	B	
	11-23	3	E	
	21-45	6	F	
23	0.8" (20 mm) Red	3-15	3	A
		6-30	6	B
		11-23	3	E
		21-45	6	F
	1.5" (38 mm) Blue	3-15	3	A
		6-30	6	B
		11-23	3	E
		21-45	6	F
	2.0" (51 mm) Green	3-15	3	A
		6-30	6	B
		11-23	3	E
		21-45	6	F
2.5" (64 mm) Yellow	3-15	3	A	
	6-30	6	B	
	11-23	3	E	
	21-45	6	F	

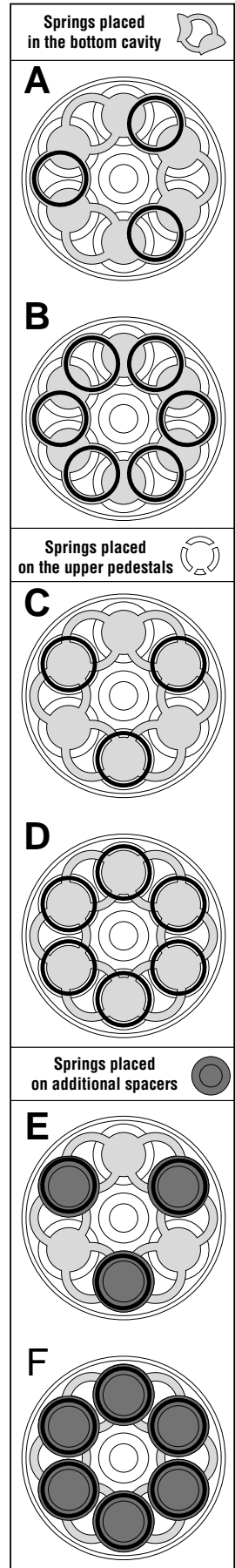

TABLE 4
Arrangement of springs into diaphragm plate according to actuator characteristics

Sales Offices and Distribution Centers

AUSTRIA

Masoneilan HP+HP GmbH
Hans-Kudlich-Str. 35
2100 Korneuburg (b. Wien)
Telephone/Fax : 43 02262 63689

BELGIUM

Masoneilan Division of Dresser Europe S.A.
281-283, Chaussée de Bruxelles
1190 BRUSSELS - Belgium
Telephone 02 344 09 70
Fax 02 344 11 23

BRAZIL

Dresser Industria E Comercio Ltda
Divisao Masoneilan
Rua Senador Vergueiro, 433
09521-320 Sao Caetano Do Sul
Sao Paulo - Brazil
Telephone 55 11 453 5511
Fax 55 11 453 5565

CANADA

Dresser Canada, Inc.
Valve & Controls Division
5010 North Service Road
Burlington, Ontario, L7L 5R5 - Canada
Telephone 1-905-335-3529
Fax 1-905-336-7628

Dresser Canada, Inc.
Valve & Controls Division
3530 78 th Avenue
Edmonton, Alberta T6B 2X9 - Canada
Telephone 1-403-465-7882
Fax 1-403-468-0934

FRANCE

Dresser Produits Industriels
Division Masoneilan
4, place de Saverne
92971 Paris La Défense Cedex - France
Telephone 33 1 49 04 90 00
Fax 33 1 49 04 90 10

Lyon Distribution Center
55, rue de la Mouche
69540 Irigny - France
Telephone 33 4 72 39 06 29
Fax 33 4 72 39 21 93

Martigues Distribution Center RN 568
13220 Chateaufort-les-
Martigues - France
Telephone 33 4 42 76 17 24
Fax 33 4 42 79 87 52

GERMANY

Masoneilan - HP+HP GmbH
P.O. Box 1208 - 47860 Willich
K.I. Kollenburg-Str. 78-80 - 47877 Willich
Germany
Telephone 49 2156 9189-0
Fax 49 2156 41058

GERMANY (Continuation)

Masoneilan HP+HP GmbH
Uhlandstr. 58
60314 Frankfurt - Germany
Telephone 49 69 439350
Fax 49 69 4970802

Masoneilan HP+HP GmbH
Goethestr. 1700
06237 Leuna - Germany
Telephone/Fax 49 03461 434443

ITALY

Masoneilan - Divisione of Dresser Italia S.p.A.
Headquarters, Sales Office,
Plant and After Sales : Via Cassano 77
80020 Casavatore (Naples) - Italy
Telephone (081) 7892111
Fax (081) 7892208

North Italy Sales Office :
C.so Garibaldi 113
20121 Milan - Italy
Telephone (02) 29005683/84
Fax (02) 29005660

JAPAN

Niigata Masoneilan Company Limited.
26th fl., Marive East Tower
WBG 2-6 Nakase Mihama-ku Chiba-shi,
Chiba, 261-71 - Japan
Telephone 81-43-297-9242
Fax 81-43-299-1115

LATIN AMERICA

Dresser Valve & Controls Division
10556 NW 26th Street, Suite D-201
Miami, Florida 33172 - U.S.A.
Telephone 1-305-470-2766
Fax 1-305-470-2743

MEXICO

Masoneilan Internacional, S.A. de C.v.
Henry Ford n° 114, Esq. Fulton
Fraccionamiento Industrial San Nicolas
54030 Tlalnepantla, Mexico
Telephone 52-5-310-9863
Fax 52-5-310-5584

MIDDLE EAST REGION

Dresser Valve & Controls Division
Middle East Operations
Unit JAO1 and JAO2 Roundabout 8
Jebel Ali Free Zone - United Arab Emirates
Telephone 971-4-838-752
Fax 971-4-838-038

NETHERLANDS

Dresser Industrial Products B.V.
Masoneilan Division
Steenhouwerstraat 11 - 3194 AG Hoogvliet
P.O. Box 640
3190 AN Hoogvliet RT - The Netherlands
Telephone 010-4384122
Fax 010-4384443

SINGAPORE

Dresser Valve & Controls Far East
16, Tuas Ave 8 - Singapore 639231
Telephone 65-861-6100
Fax 65-861-7172

SOUTH AFRICA

Dresser Limited
Valve & Controls Division
P.O. Box 2234 - 16 Edendale Road
Eastleigh, Edenvale 1610
Transvaal, Republic of South Africa
Telephone 27-11-452-1550
Fax 27-11-452-2903

SPAIN

Masoneilan S.A.
Zona Franca, Sector M, Calle Y
08040 Barcelona - Spain
Telephone 34 3 223 41 75/223 41 28
Fax 34 3 223 47 54

UNITED KINGDOM

Valve & Controls - Dresser U.K. Ltd.
Trevithick Works
Gillibrands Estate, Skelmersdale
Lancashire WN8 9TU - England
Telephone 44-1695-52600
Fax 44-1695-720175

Valve & Controls - Dresser U.K. Ltd.
U.K. Sales Office :
Unit 5, Brook Business Centre
Cowley Mill Road, Uxbridge
Middle UB8 2FX - England
Telephone 44-1895-454900
Fax 44-1895-454919

UNITED STATES

Dresser Valve & Controls Division
Masoneilan North America Operations
85 Bodwell Street
Avon, Massachusetts 02322-1190
Telephone 1-508-586-4600
Fax 1-508-941-5497

Dresser Valve & Controls Division
15112 Morales Road (77032)
P.O. Box 60078
Houston, Texas 77205-0078
Telephone 1-281-871-6500
Fax 1-281-871-6569

Masoneilan is an international leader in the design, manufacture, and support of final control elements and solutions for efficient process automation. Masoneilan is an integral part of Dresser Industries' Valve & Controls Division (DVCD), which also includes the Nil-Cor and Industrial Valve Operations. DVCD provides a comprehensive portfolio of control valves, corrosion resistant valves, pressure relief valves, and intelligent field instrumentation.

Masoneilan

Valve & Controls 

Experience, Knowledge & Technology...In Control.